

BILL OF MATERIALS

ITEM	QTY.	DESCRIPTION	PART No.	SUFFIX
1	1	C.J. ANDERSON HG-1 INTERLOCK (R.H.)	1289	
2*	1	INTERLOCK LINKAGE ARM	1283	
3*	1	INTERLOCK LINKAGE ROD	1284	
4	1	INTERLOCK LATCH BRACKET	1285	
5	2	UNISTRUT NUT FOR P3300 CHANNEL, 1/4-20	1286	
6	2	HHCS, 1/4-20 x 1" LG.		
7*	2	HHCS, 5/16-18 x 1 1/4" LG.		
8*	2	HEX NUT, 5/16-18		
9*	2	LOCK WASHER, 5/16"		
10*	2	FLAT WASHER, 5/16"		
11	2	FLAT WASHER, 1/4"		

* - THESE ITEMS ARE ONLY REQUIRED WHEN THE INTERLOCK ENGAGEMENT NEEDS TO BE EXTENDED.

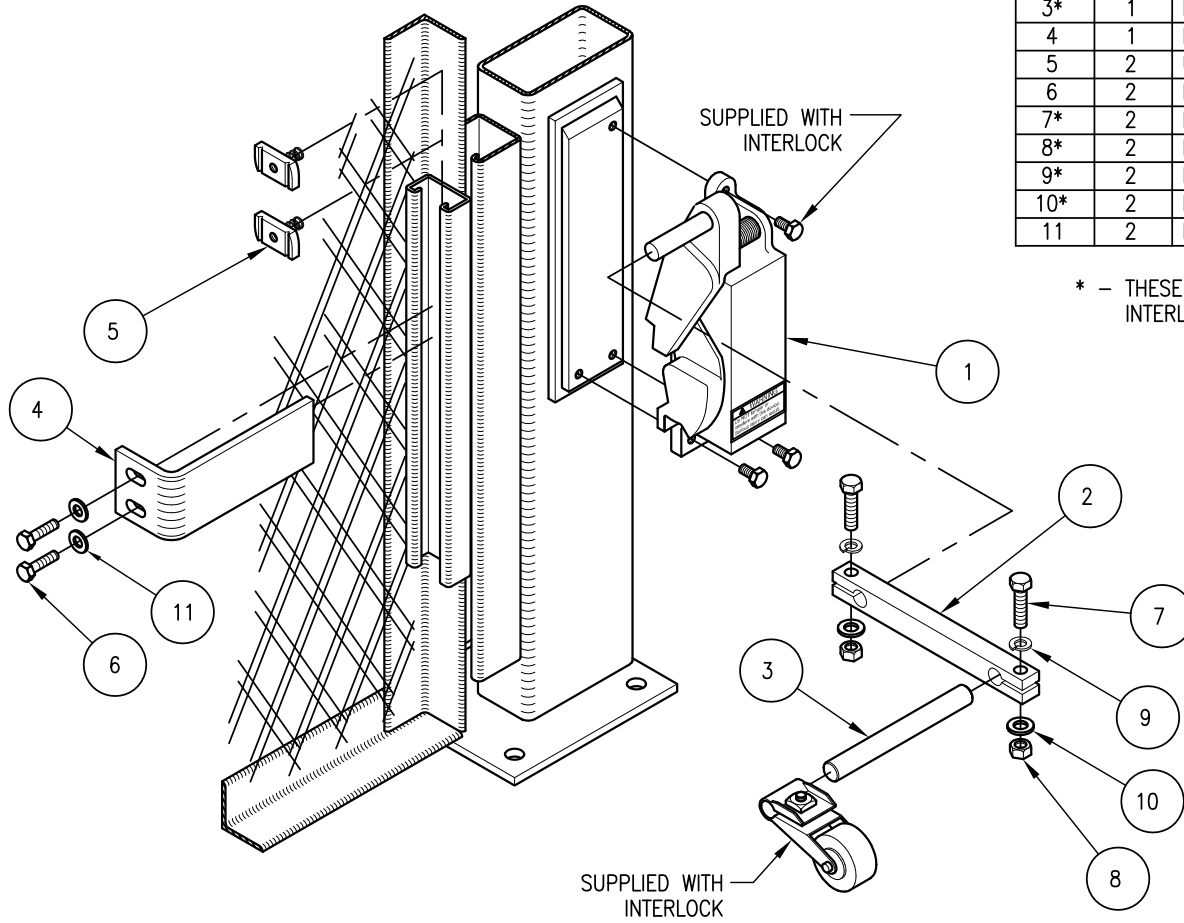

HG-1 INTERLOCK ASSEMBLY (R.H.)
FOR VERTICAL ACTING GATE

DATE: 10-24-91
DRN BY DFK

1288-IB 1
REV 1