

BILL OF MATERIALS

ITEM	QTY.	DESCRIPTION	PART No.	SUFFIX
1	1	DRIVE CHAIN (SIZE VARIES)		
2	1	#35 CHAIN		
3	1	CONNECTION BLOCK FOR DRIVE CHAIN	VARIES	
4	1	1/4" CHAIN SWIVEL	1488	
5	1	MASTERLINK, #35 TENSION CHAIN	2244	
6	1	S-HOOK, 3/16" x 1 3/4"	A-HWM1350	
7	1	S-HOOK, 5/32" x 1 3/8"	HWM1360	
8	1	EYEBOLT, 1/4"-20 X 4" LG.	HWM1010	
9	2	HEX NUT, 1/4"-20		
10	2	MASTER LINK FOR DRIVE CHAIN	VARIES	

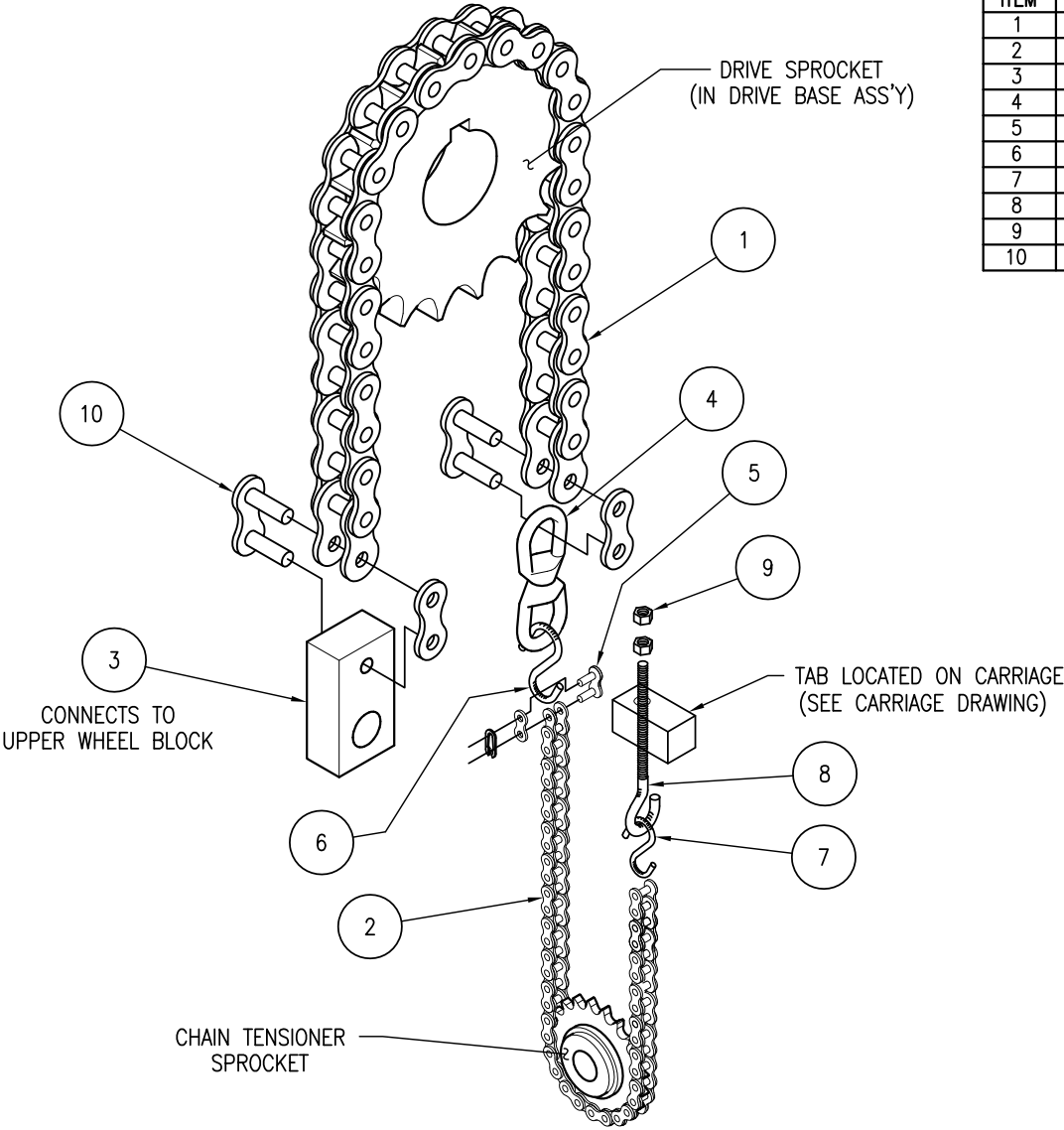

NOTE:
 2 CHAINS REQ'D.
 FOR CANTILEVER AND
 STRADDLE LIFTS

4 CHAINS REQ'D.
 FOR 4-POST LIFT



CHAIN ASSEMBLY

DATE: 5-11-92
 DRN BY DFK

1321

REV
1